

# SC

## Mast climbing work platform option **Glide Rail**

Scanclimber's glide rail is an additional equipment meant for the mast climbing work platform (MCWP) which helps to move and deliver facade elements on the platform at any given height. The glide rail has a simple design and it is easy to install. The add-on is compatible with all the middle to high payload range capacity Scanclimber MCWPs. (SC5000, SC6000, SC8000 & SC10000)

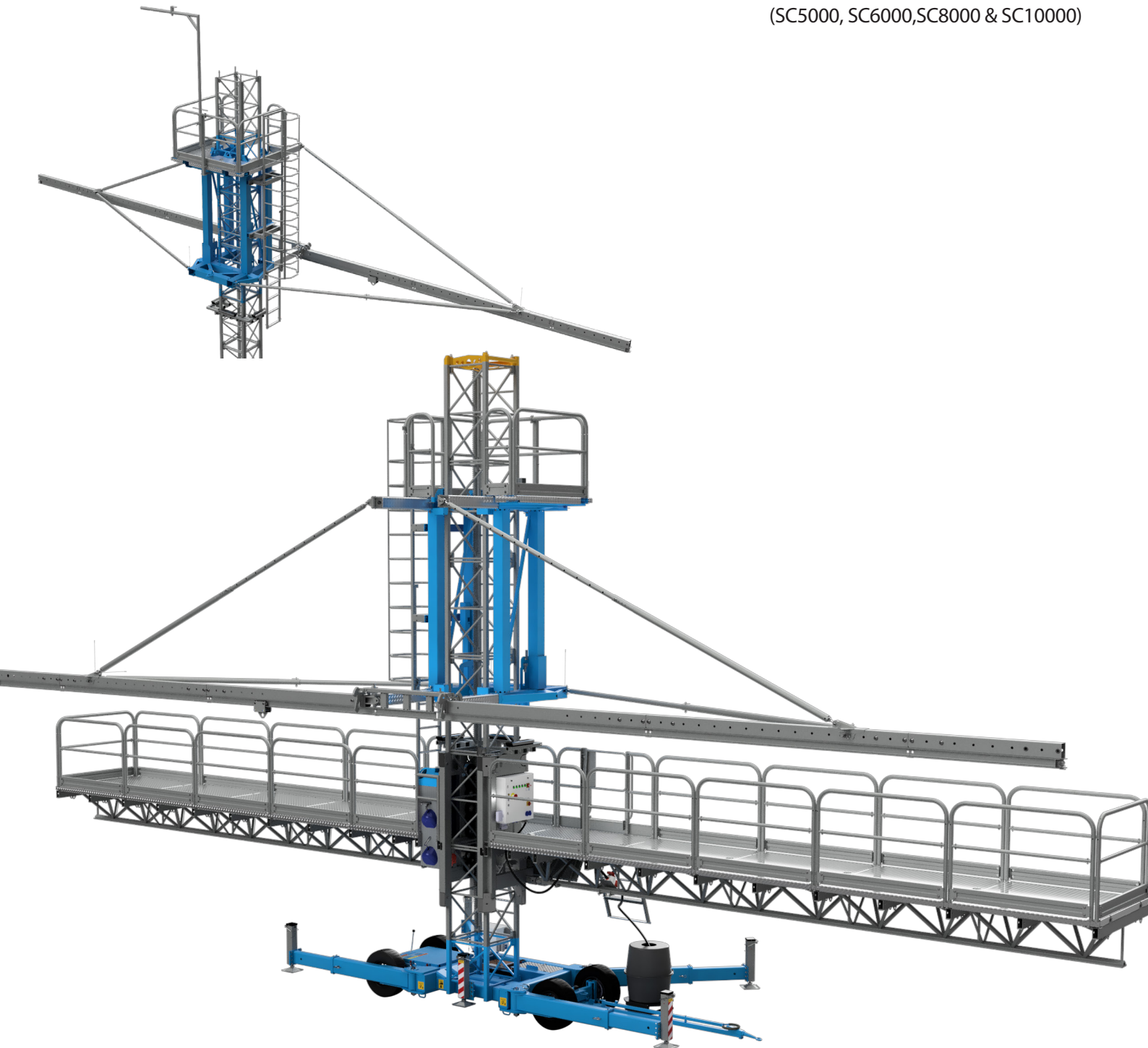

**SCANCLIMBER**®  
by Tractel®

### General

The glide rail is a special mast climbing work platform (MCWP) add-on that helps to lift and deliver facade elements (such as glass/concrete panels) at any given height. The frame of glide rail system is mounted to the mast, above the lifting frame of mast climber. MCWP is used to lift and lock the glide rail to the desired height/position on the mast. Once the glide rail is locked to the mast, the MCWP is free to move and take the maximum load.

The glide rail can be equipped with a lifting device such as a chain hoist or wire rope hoist. The installed chain hoist can move along the glide rail and help lifting and transporting materials from the platform to the facade.

### Advantages

- Glide rail is very stable, robust and has a modular design and is easy to install on the MCWP.
- Glide rail helps to cut down the use of expensive crane hours.
- Glide rail is compatible with all the latest MCWPs by Scanclimber and can be used on both single and twin MCWP configurations.
- Glide-rail has an extension system which allows the rail to be moved from the edge of the platform towards the building.
- The openable hatch allows the glide rail to pass through the wall anchors, making it easy to install and easy to use with anchored masts.

### Payloads and Dimensions

**The glide rail has a maximum payload of 1000 kg.** It can be lifted up to a desired working height with the platform and locked to the mast. When glide rail is locked to the mast, it does not have any effect on the payload capacity of the MCWP.

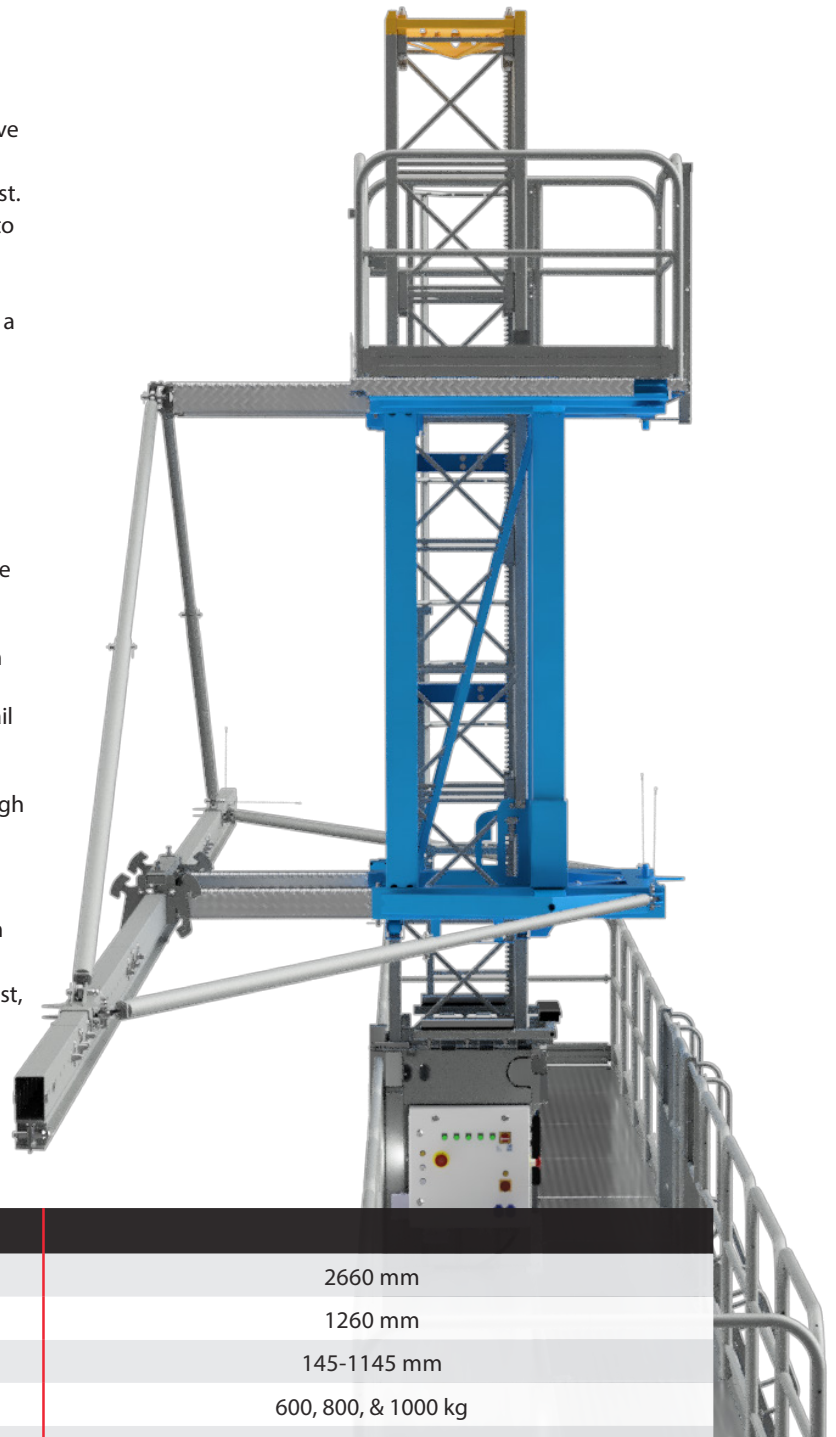

## Technical Data

Height frame	2660 mm
Width frame	1260 mm
Distance between the glide rail and the wall	145-1145 mm
Payload range (depending on rail length)	600, 800, & 1000 kg
Free standing	Not allowed
Maximum anchor spacing	Depends on platform and application
Maximum overhang after the last anchor	6,25 m
Maximum width	Single platform : 16 m Twin platform : 32 m

Scanclimber is the world's technology leader in mast climbing equipment for both temporary and permanent installations. The company has its corporate head office in Pirkkala, Finland, and manufacturing in Gniezno, Poland.

The company employs more than 200 people in Europe and Asia.

Scanclimber creates value for its customers with high quality, reliable and flexible vertical access solutions.

**SCANCLIMBER**®  
by Tractel®

Scanclimber Oy, Turkkirata 26, FI-33960 Pirkkala | [www.scanclimber.com](http://www.scanclimber.com)

Tel. +358 10 680 7000, Fax +358 10 680 7033